

Automatan

BY INSPIRE AUTOMATION



LOAD INVERTERS

Whether turning loads for downstream operations, changing pallets or inserting slip sheets, manual handling of large loads can be time consuming and expensive. The Automatan Load Inverter (LHE) reduces these tasks to a simple one-person operation taking only a fraction of the time required for manual stacking. Compared to handling pallet size loads manually, Automatan LHE can reduce labor costs and provide substantial ergonomic benefits. Using circular steel side frames cradled on heavy rollers, one electric motor effortlessly turns even the largest loads. Each load is securely held within the turner by a platen, and

the entire machine rotates on the cradle. Light curtains ensure safety. Interrupting the photo beams will stop machine rotation and platen operation until the area is clear and the reset buttons have been pressed. In addition to our standard load turners, we have designed special applications including power roller conveyors on the base and platen for automated line installation and center axis inverting and automatic pallet clamping. Automated or manual push button operation allows a single operator to easily invert pallet sized loads in seconds. Fully automated machines can be supplied or integrated into existing conveyor systems.

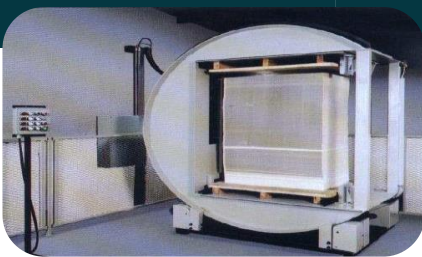

SIMPLE OPERATION

Automatan Load Inverters (LHE) are designed for one-person handling of Pallet-sized loads.



APPLICATION FLEXIBILITY

Automatan Load Inverters (LHE) can be stand-alone with throat entry and discharge, or in-line with the material handling system for automatic infeed and discharge.

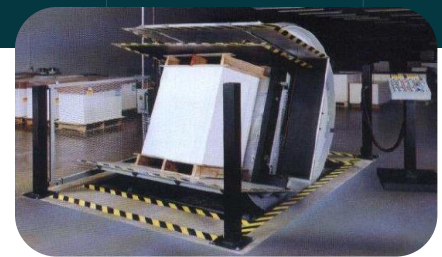

PIT REQUIREMENT

Automatan Load Inverters (LHE) are installed in a shallow pit for easy floor level loading using a standard pallet jack.

LOAD INVERTERS

SPECIFICATIONS

MODEL	LOAD SPECIFICATIONS			MACHINE SPECIFICATIONS				
	Maximum Format A B	Maximum Pile Height Including Pallet C	Capacity	Width of Opening D	Length of Opening E	Height of Opening F	Machine Weight	Amps at 440 Volts
A73T	59" x 78" (1500 x 1980mm)	67" (1700mm)	4500 lbs (2040 kg)	59" (1500mm)	78" (1980mm)	73" (1850mm)	7000 lbs (3175 kg)	15 amps
A83T	59" x 78" (1500 x 1980mm)	77" (1960mm)	5500 lbs (2490 kg)	59" (1500mm)	78" (1980mm)	83" (2100mm)	7800 lbs (3540 kg)	20 amps
A83TCP*	70" x 120" (1778 x 3048mm)	73" (1855mm)	3000 lbs* (1361 kg)	74" (1880mm)	120" (3048mm)	80" (2032mm)	14,000 lbs (6350 kg)	20 amps

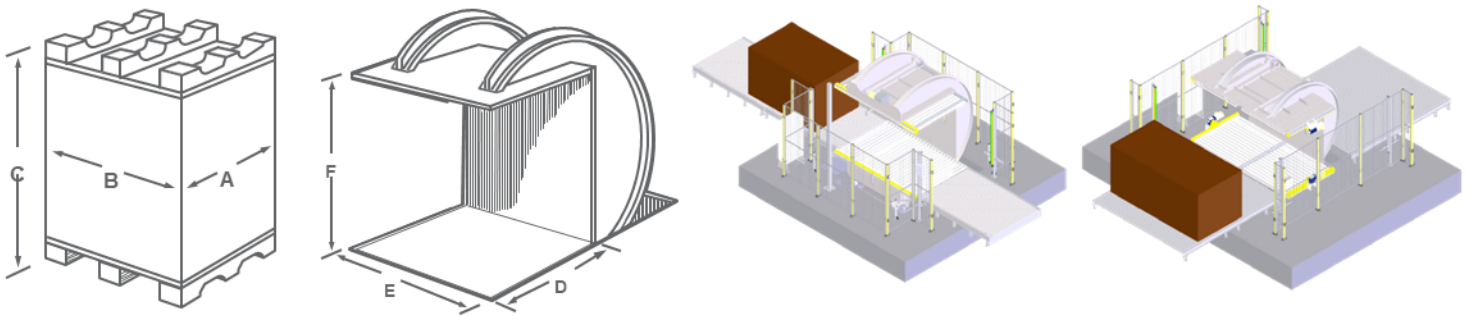

Note: Automatan Load Inverters can be designed for special application requirements. Ask your sales representative for details.

*The A83TCP inverter is designed for large sheets and comes equipped with two full length sections of roller conveyor that extend beyond the width of the machine. The extra weight of the conveyors effects for the weight capacity and the machine weight, noted in the chart above. The machine space requirements listed in the chart below includes guarding that comes standard around the A83TCP.

CONSTRUCTION

Machine space requirements and recommended** minimum clearance from stationary objects.

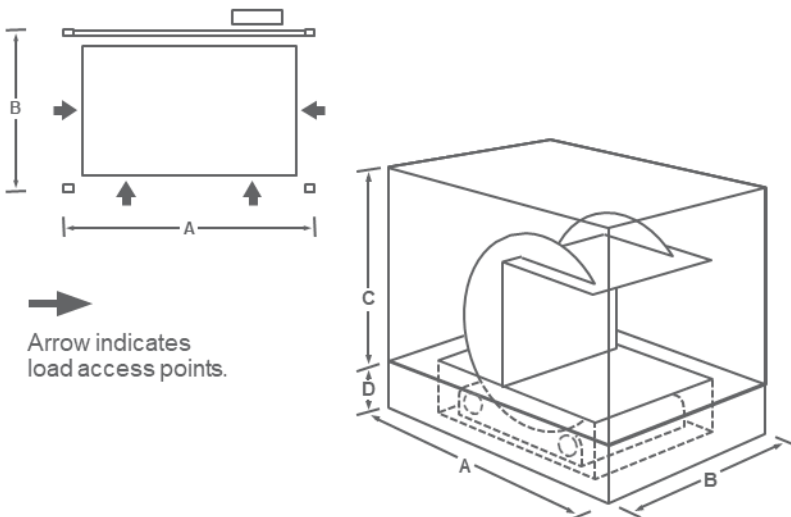

Arrow indicates load access points.

Size	A	B	C	D
A73T	144" (3660mm)	120" (3050mm)	94" (2390mm)	19" (480mm)
A83T	150" (3810mm)	120" (3050mm)	104" (2640mm)	19" (480mm)
A83TCP*	185" (4699mm)	206"* (5232mm)	125" (3175mm)	23.5" (597mm)

**These measurements represent minimum operational clearances from building support columns, overhead trusses, beams, and utilities. Additional space adequate for loading/unloading, electrical cabinet and operator convenience must be allowed. The product, product flow, and pallet handling equipment in each plant affect additional space requirements for loading/unloading in your facility. Note: While these specifications may be used for general site planning, they SHOULD NOT be used for site preparations. All specifications are subject to change without notice.